

## CE 1100

P/N: 8140977

### Tool Features

- Automatic on/off actuation when landing and placing the workpiece in *AUTO mode*.
- 5:1 safety factor.
- Fails safe – no power required once actuated.
- 800 operation cycles before recharging 2h by power supply of 110V / 230V.
- Variable Flux Output (VFO) for de-stacking (1/4in min)
- On tool button or by wireless remote control

**IMPORTANT note ASME B30.20 standards take precedence over all data provided. We strongly advise operators to be familiar with this standard prior to using any underhook lifter.**

- Do not actuate the tool off target.
- The magnetic surface of the lifter must be fully covered by the target when it is actuated.
- Reference the chart to see reduced hold force on thinner material.
- Ensure the surface is clean and free of debris to maximize magnetic hold.

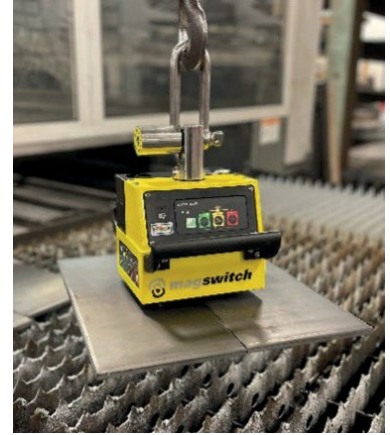

### Specifications

<b>Maximum Breakaway Force</b> <sup>1,2</sup>	3300lb / 1500 kg
<b>Breakaway Force @ SWL 5:1</b>	660lb / 300kg
<b>Minimum Thickness for De-Stacking<sup>3</sup> – VFO capable</b>	Level 1: 1/4in / 6mm Level 2: 5/16in / 8mm Level 3: 13/32in / 10mm
<b>Charging Supply Voltage</b>	110V/230V
<b>Charging Time</b>	2 hours
<b>Number of Cycles per Charge</b>	800
<b>Net Weight</b>	55lb / 25kg
<b>Mounting Option</b>	Single Hoist Ring
<b>Hold Surface (L x W)</b>	5.7in x 5in
<b>Dimensions (L x W x H)</b>	7in x 6.3in x 5.5in

**1.** Determined in laboratory environment on SAE1018 Steel with surface roughness 63 micro inches with optimized pole shoes. Many factors contribute to the actual breakaway force and safe working load in each application. Consult a MagSwitch Applications Engineer and test the MagSwitch in each application before deployment.

**2.** All data applies to unit with standard combination V/flat pole shoes installed.

**3.** Determined with SAE1018 Steel L=200mm W=200mm.

**4.** Maximum forces listed above are not safe lifting forces. Designer must take into account safety factor when specifying tool. MagSwitch recommends SWL = 5:1 for most lifting applications.

$$\text{SWL (Safe Working Load)} = \frac{\text{Maximum Force}^4}{\text{Safety Factor} (\geq 5)}$$

# CE 1100

P/N: 8140977

## Specifications

CE1100	Air gap <0.1mm	Air gap 0.1 to 0.3mm	Air gap 0.3 to 0.5mm
Material Thickness mm [in]	Max. Load kg [lbs]	Max. Load kg [lbs]	Max. Load kg [lbs]
4 [0.157]	55 [121]	50 [110]	50 [110]
6 [0.236]	105 [231]	100 [220]	90 [198]
10 [0.393]	235 [518]	225 [496]	205 [451]
16 [0.629]	375 [826]	360 [793]	330 [727]
20 [0.787]	415 [914]	395 [870]	360 [793]
25 [0.984]	445 [981]	425 [936]	380 [837]
40 [1.574]	500	470	415 [914]

## Drawings

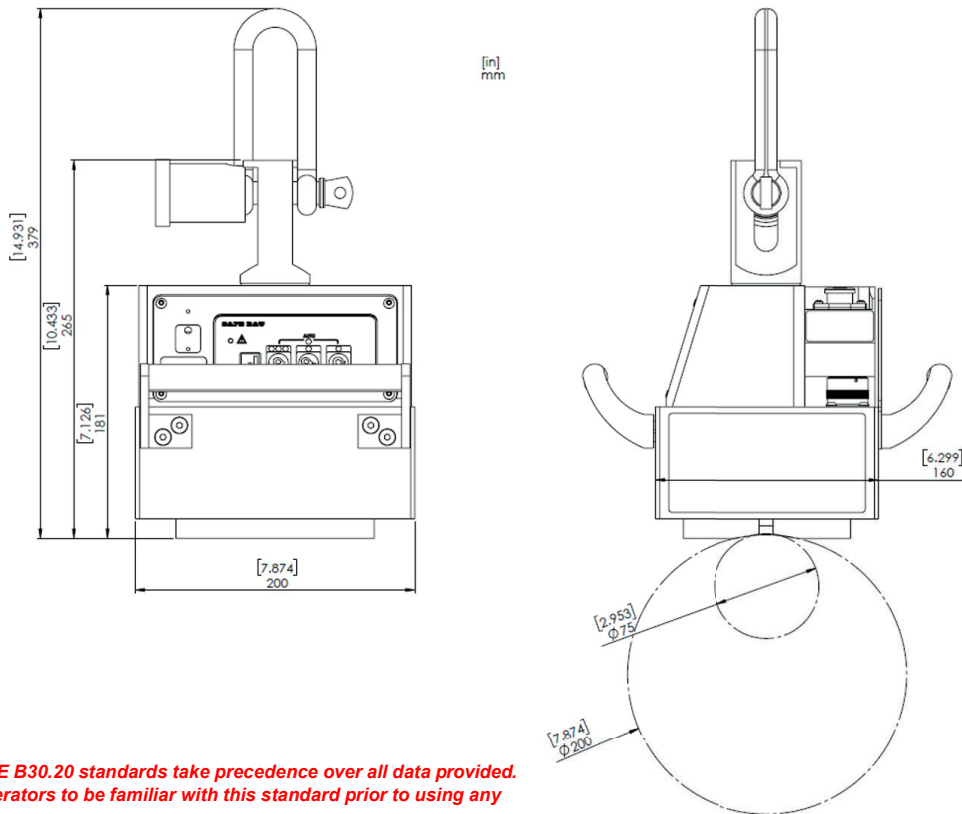

**IMPORTANT note ASME B30.20 standards take precedence over all data provided. We strongly advise operators to be familiar with this standard prior to using any underhook lifter.**

MAGSWITCH TECHNOLOGY INC. | 1000 S. McCaslin Blvd, Suite 301 | Superior Colorado 80027 | United States | +1 (303) 468.0662 | sales@magswitch.com

CE 1100  
8140977 / REV03

Subject to technical and color changes. No liability for errors and misprints assumed. © Magswitch Technology Inc. 2023