



Air Atomizing Spray Nozzles

Siphon Fed Round Pattern - 1/4 NPT



Model: SR1010SS
Material: Type 303 Stainless Steel

Model: SR1020SS
Material: Type 303 Stainless Steel

Model: SR1030SS
Material: Type 303 Stainless Steel

Model: SR1040SS
Material: Type 303 Stainless Steel

Model SR1010SS, SR1020SS, SR1030SS and SR1040SS

1/4 NPT siphon fed round pattern nozzles are great where no liquid pressure is available and a thin coating is needed at a specific area. Flow rate is adjustable via the adjusting valve. Siphon nozzles work best with a suction height of 36" (914mm) or less. Since these nozzles are siphon fed, the compressed airflow draws the liquid in and mixes it internally. Liquid flow is dependent both on the gravity or suction height and the airflow. Siphon fed round pattern nozzles provide the most liquid flow of any siphon fed nozzle.

Siphon or gravity fed for non-pressurized applications.



The SR1020SS has a focused, round pattern for precision application of coatings or coolant.

Dimensions and Airflow Pattern

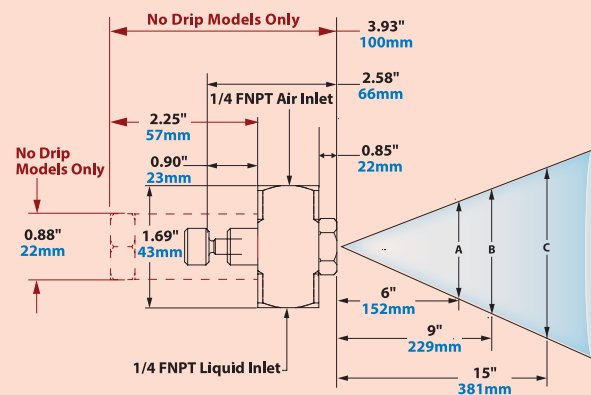

No Drip Only Dimensions in Red
 See page 93 for No Drip Atomizing Nozzles

Liquid Flow in GPH/LPH													Spray Dimensions at 8" (20cm) Siphon Height																	
Model	Air				Gravity Head					Siphon Height									Air Pressure PSI/BAR	Width						Max. Depth feet/m				
	Pressure PSI/BAR	SCFM/SLPM	18"	46cm	12"	30cm	6"	15cm	4"	10cm	8"	20cm	12"	30cm	24"	61cm	36"	91cm		A in	B in	C in								
SR1010SS	10	0.7	0.5	14.2	0.6	2.3	0.5	1.9	0.4	1.5	0.2	0.8	0.2	0.8	---	---	---	---	10	0.7	2.5	6	4.0	10	5.8	15	7	2.1		
	20	1.4	0.7	19.8	0.6	2.3	0.6	2.3	0.5	1.9	0.4	1.5	0.4	1.5	0.3	1.1	---	---	---	20	1.4	3.3	8	4.3	11	6.0	15	9	2.7	
	40	2.8	1.2	34.0	0.7	2.6	0.7	2.6	0.6	2.3	0.5	1.9	0.5	1.9	0.4	1.5	0.3	1.1	0.2	0.8	40	2.8	3.8	10	5.0	13	6.8	17	10	3.0
	60	4.1	1.6	45.3	0.8	3.0	0.8	3.0	0.7	2.6	0.6	2.3	0.5	1.9	0.5	1.9	0.4	1.5	0.2	0.8	60	4.1	3.8	10	5.0	13	6.8	17	11	3.4
SR1010SS	10	0.7	0.7	19.8	1.1	4.2	0.9	3.4	0.8	3.0	0.5	1.9	0.4	1.5	0.3	1.1	---	---	---	10	0.7	3.3	8	4.8	12	6.8	17	9	2.7	
	20	1.4	1.1	31.1	1.3	4.9	1.1	4.2	1.0	3.8	0.8	3.0	0.7	2.6	0.6	2.3	0.3	1.1	---	---	20	1.4	3.5	9	5.0	13	7.0	18	11	3.4
	40	2.8	1.7	48.1	1.6	6.1	1.5	5.7	1.4	5.3	1.2	4.5	1.0	3.8	1.0	3.8	0.7	2.6	0.4	1.5	40	2.8	3.8	10	5.5	14	7.5	19	14	4.3
	60	4.1	2.3	65.0	1.9	7.2	1.7	6.4	1.6	6.1	1.4	5.3	1.2	4.5	1.2	4.5	0.9	3.4	0.5	1.9	60	4.1	4.0	10	5.8	15	8.0	20	16	4.9
SR1030SS	20	1.4	2.0	56.6	4.3	16.3	3.8	14.4	3.3	12.5	2.5	9.5	1.8	6.8	1.3	4.9	0.3	1.1	---	---	20	1.4	3.5	9	5.0	13	7.0	18	12	3.7
	40	2.8	3.2	90.6	5.0	18.9	4.4	16.7	4.0	15.1	3.3	12.5	2.9	11.0	2.5	9.5	1.3	4.9	1.0	3.8	40	2.8	3.8	10	5.3	13	7.5	19	13	4.0
	60	4.1	4.3	122	5.5	20.8	4.9	18.5	4.5	17.0	3.7	14.0	3.4	12.9	3.1	11.7	1.9	7.2	1.5	5.7	60	4.1	3.8	10	5.5	14	8.0	20	15	4.6
	80	5.5	5.6	158	5.8	22.0	5.3	20.1	4.9	18.5	4.1	15.5	3.9	14.8	3.7	14.0	2.6	9.8	1.7	6.4	80	5.5	4.0	10	5.8	15	8.3	21	18	5.5
SR1040SS	30	2.1	5.7	161	12.3	46.6	11.0	41.6	9.3	35.2	6.3	23.8	5.3	20.1	4.5	17.0	0.6	2.3	---	---	30	2.1	4.8	12	6.5	17	8.8	22	19	5.8
	40	2.8	6.9	195	13.0	49.2	11.8	44.7	10.0	37.9	7.3	27.6	6.5	24.6	5.5	20.8	1.5	5.7	0.3	1.1	40	2.8	5.2	13	7.0	18	9.3	24	21	6.4
	60	4.1	9.5	269	14.3	54.1	13.0	49.2	11.5	43.5	8.5	32.2	7.5	28.4	6.5	24.6	2.3	8.7	1.5	5.7	60	4.1	5.5	14	7.5	19	9.8	25	24	7.3
	80	5.5	12.0	340	15.0	56.8	13.5	51.1	12.5	47.3	9.5	36.0	8.5	32.2	7.5	28.4	3.5	13.2	1.9	7.2	80	5.5	5.8	15	7.8	20	10.0	25	27	8.2



No Drip Air Atomizing Spray Nozzles



No Drip Air Atomizing Spray Nozzles



Eliminate drips to conserve valuable liquids and improve product finishes!

What Are No Drip Atomizing Nozzles?

EXAIR's patented† no drip atomizing spray nozzles work in the same way our standard atomizing nozzles do, but have the added benefit of positively stopping liquid flow when compressed air is shut off. All models use stainless steel construction for durability and corrosion resistance.

EXAIR's no drip atomizing nozzles are available in 3 basic families:

Internal Mix:

Internal mix nozzles mix the liquid and air inside the air cap and produce the finest atomization. Internal mix nozzles can be used on liquids with a viscosity up to 300 cP. Both air and liquid sides are pressure fed. **No Drip Internal Mix Atomizing Nozzles are for pressure fed applications not requiring independent air and liquid control.**

External Mix:

External mix nozzles have the highest flow rates and allow the air and liquid flows to be adjusted independently. These nozzles are best where precise liquid flow is needed. External mix nozzles can be used on liquids with a viscosity above 300 cP. Both air and liquid sides are pressure fed. **No Drip External Mix Atomizing Nozzles are for pressure fed applications with independent air and liquid control.**

Siphon Fed:

Siphon fed nozzles require no liquid pressure and can be used with gravity fed liquids or lift liquids from a siphon height as much as 36 inches (91cm). Siphon fed nozzles can be used on liquids with a viscosity up to 200 cP. **No Drip Siphon Fed Atomizing Nozzles are siphon or gravity fed for non-pressurized applications.**

† Patent #9156045

Why No Drip Atomizing Nozzles?

When spraying any type of liquid, post-spray liquid flow can cause big problems. Unwanted drips can ruin product finishes on painted or coated surfaces. In addition, excess liquid flow wastes precious resources such as expensive coatings, chemicals or water. EXAIR's no drip atomizing nozzles are ideal where no post-spray drip is permissible. When the compressed air supply is shut off, the no drip nozzle positively seals off the flow of liquid eliminating the possibility of drips. They can be used in any situation that our standard atomizing nozzles can be used, including Siphon Fed applications. Unlike some manufacturers, there's no need to run a separate air line to control the no drip mechanism. The same compressed air used to combine and atomize liquid in a variety of patterns is used to open a valve allowing liquid to flow. That makes these ideal for use with EXAIR's money and energy saving EFC (see page 7).

EXAIR's no drip nozzles do not change flow rates from standard atomizing nozzles. Operations that require up to 180 cycles per minute can be achieved. Minimum operating air pressure of 30 PSIG (2.1 BAR) required for 1/4 and 1/2 NPT nozzles. 20 PSIG (1.4 BAR) is required for 1/8 NPT nozzles.

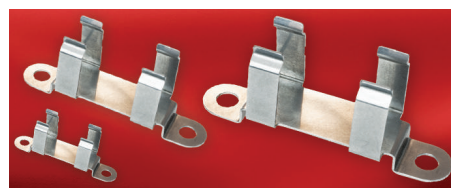

Mounting Brackets are available - Model 901786 for 1/8 NPT, Model 901318 for 1/4 NPT and Model 901556 for 1/2 NPT atomizing nozzles.



Applications

- Painting
- Coating
- Rinsing
- Cooling
- Quenching
- Wetting (moistening)
- Humidification
- Dust Control

Advantages

- No post spray drip
- Adjustable
- Easily used with an EFC
- Minimizes air and liquid consumption
- All stainless steel construction
- Fine atomization
- Interchangeable liquid and air caps
- Compact





No Drip Air Atomizing Spray Nozzles

No Drip Siphon Fed Atomizing Nozzles are siphon or gravity fed for non-pressurized applications.



Spray Nozzles

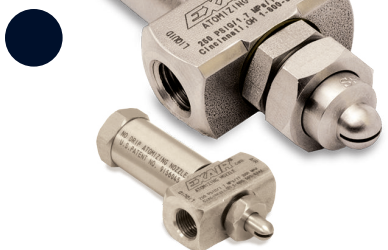
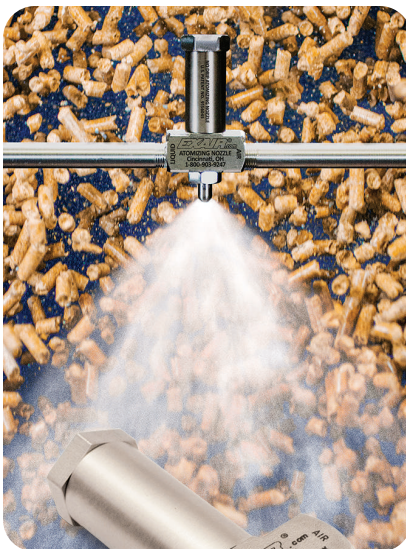

Model	Description
-------	-------------

No Drip Siphon Fed Round Pattern Atomizing Nozzles

SR9010SS	No Drip Siphon Fed Round Pattern Atomizing Nozzles, 0.53 GPH/2.02 LPH Max, 1/8 NPT
SR9020SS	No Drip Siphon Fed Round Pattern Atomizing Nozzles, 0.96 GPH/3.63 LPH Max, 1/8 NPT
SR9030SS	No Drip Siphon Fed Round Pattern Atomizing Nozzles, 1.98 GPH/7.50 LPH Max, 1/8 NPT
SR9040SS	No Drip Siphon Fed Round Pattern Atomizing Nozzles, 4.09 GPH/15.48 LPH Max, 1/8 NPT
SR9050SS	No Drip Siphon Fed Round Pattern Atomizing Nozzles, 5.12 GPH/19.38 LPH Max, 1/8 NPT
SR2010SS	No Drip Siphon Fed Round Pattern Atomizing Nozzles, 0.8 GPH/3.0 LPH Max, 1/4 NPT
SR2020SS	No Drip Siphon Fed Round Pattern Atomizing Nozzles, 1.9 GPH/7.2 LPH Max, 1/4 NPT
SR2030SS	No Drip Siphon Fed Round Pattern Atomizing Nozzles, 5.8 GPH/22.0 LPH Max, 1/4 NPT
SR2040SS	No Drip Siphon Fed Round Pattern Atomizing Nozzles, 15.0 GPH/56.8 LPH Max, 1/4 NPT
SR6010SS	No Drip Siphon Fed Round Pattern Atomizing Nozzles, 68.3 GPH/259 LPH Max, 1/2 NPT

NO DRIP SIPHON FED ATOMIZING NOZZLES

No Drip Siphon Fed Flat Fan Pattern Atomizing Nozzles

SF9010SS	No Drip Siphon Fed Flat Fan Pattern Atomizing Nozzles, 0.43 GPH/1.62 LPH Max, 1/8 NPT
SF9020SS	No Drip Siphon Fed Flat Fan Pattern Atomizing Nozzles, 1.52 GPH/5.75 LPH Max, 1/8 NPT
SF9030SS	No Drip Siphon Fed Flat Fan Pattern Atomizing Nozzles, 1.45 GPH/5.49 LPH Max, 1/8 NPT
SF2010SS	No Drip Siphon Fed Flat Fan Pattern Atomizing Nozzles, 0.4 GPH/1.5 LPH Max, 1/4 NPT
SF2020SS	No Drip Siphon Fed Flat Fan Pattern Atomizing Nozzles, 1.2 GPH/4.5 LPH Max, 1/4 NPT
SF2030SS	No Drip Siphon Fed Flat Fan Pattern Atomizing Nozzles, 1.9 GPH/7.2 LPH Max, 1/4 NPT