

Air Atomizing Spray Nozzles



Siphon Fed Flat Fan Pattern - 1/4 NPT



Model: SF1010SS
Material: Type 303 Stainless Steel

Model: SF1020SS
Material: Type 303 Stainless Steel

Model: SF1030SS
Material: Type 303 Stainless Steel

Model SF1010SS, SF1020SS and SF1030SS

1/4 NPT siphon fed flat fan pattern nozzles are great where no liquid pressure is available and a thin coating is needed over a wide band. Flow rate is adjustable via the adjusting valve. Siphon nozzles work best with a suction height of 36" (914mm) or less. Since these nozzles are siphon fed, the compressed airflow draws the liquid in and mixes it internally. Liquid flow is dependent both on the gravity or suction height and the airflow. Siphon fed flat fan pattern nozzles are the best choice where liquid is needed over a broad band such as a moving assembly line.

Siphon or gravity fed for non-pressurized applications.

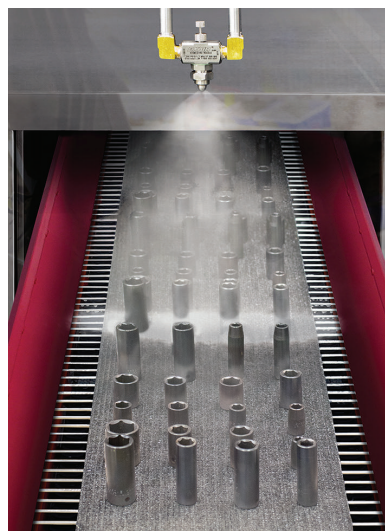

A Model SF1020SS is used to apply a light coating of oil to prevent sockets from rusting prior to a packaging operation.

Dimensions and Airflow Pattern

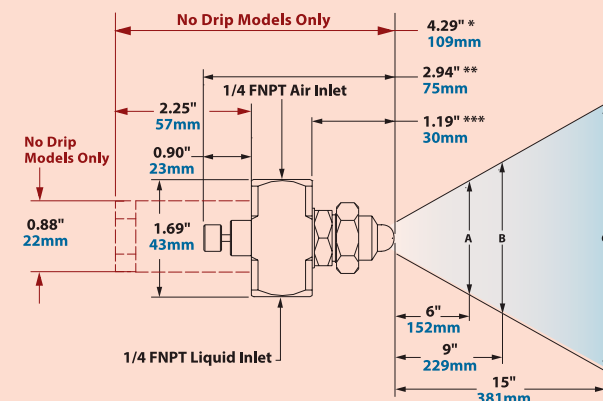

DOWNLOAD drawings at EXAIR.com

Spray Nozzles

*Model SF2010SS: 4.15" / 105mm
 **Model SF1010SS: 2.80" / 71mm
 ***Model SF1010SS: 1.05" / 27mm

No Drip Only Dimensions in Red
 See page 93 for No Drip Atomizing Nozzles

Model	Liquid Flow in GPH/LPH																		Spray Dimensions at 8" (20cm) Siphon Height											
	Air				Gravity Head						Siphon Height								Air Pressure PSI/BAR	Width			Max. Depth feet/m							
	Pressure PSI/BAR	SCFM/SLPM	18"	46cm	12"	30cm	6"	15cm	4"	10cm	8"	20cm	12"	30cm	24"	61cm	36"	91cm		A in/cm	B in/cm	C in/cm								
SF1010SS	10	0.7	0.9	25.5	0.4	1.5	0.3	1.1	0.3	1.1	0.2	0.8	0.2	0.8	0.2	0.8	0.2	0.8	0.1	0.4	10	0.7	9	23	11	28	13	33	5	1.5
	20	1.4	1.3	36.8	0.4	1.5	0.3	1.1	0.3	1.1	0.3	1.1	0.3	1.1	0.3	1.1	0.2	0.8	0.2	0.8	20	1.4	10	25	12	30	14	36	6	1.8
	30	2.1	1.7	48.1	0.3	1.1	0.3	1.1	0.3	1.1	0.3	1.1	0.3	1.1	---	---	---	---	---	---	30	2.1	11	28	13	33	15	38	7	2.1
SF1020SS	20	1.4	2.3	65.1	1.2	4.5	1.1	4.2	1.0	3.8	0.9	3.4	0.8	3.0	0.8	3.0	0.6	2.3	0.5	1.9	20	1.4	10	25	14	36	19	48	6	1.8
	30	2.1	2.9	82.1	1.1	4.2	1.1	4.2	1.0	3.8	0.8	3.0	0.8	3.0	0.8	3.0	0.6	2.3	0.5	1.9	30	2.1	11	28	15	38	21	53	7	2.1
	40	2.8	3.5	99.1	1.0	3.8	0.9	3.4	0.8	3.0	0.7	2.6	0.7	2.6	0.7	2.6	0.5	1.9	0.4	1.5	40	2.8	13	33	16	41	23	58	6	1.8
	50	3.4	4.3	122	0.8	3.0	0.7	2.6	0.5	1.9	0.5	1.9	0.4	1.5	0.3	1.1	---	---	---	---	50	3.4	14	36	18	46	25	64	6	1.8
SF1030SS	20	1.4	2.2	62.3	1.8	6.8	1.6	6.1	1.5	5.7	1.4	5.3	1.4	5.3	1.3	4.9	1.1	4.2	1.0	3.8	20	1.4	9	23	11	28	15	38	8	2.4
	30	2.1	2.8	79.2	1.9	7.2	1.8	6.8	1.8	6.8	1.7	6.4	1.7	6.4	1.6	6.1	1.4	5.3	1.2	4.5	30	2.1	10	25	13	33	17	43	9	2.7
	40	2.8	3.3	93.4	1.8	6.8	1.8	6.8	1.7	6.4	1.6	6.1	1.6	6.1	1.5	5.7	1.3	4.9	1.2	4.5	40	2.8	11	28	14	36	17	43	10	3.0
	50	3.4	4.0	113	1.6	6.1	1.5	5.7	1.4	5.3	1.4	5.3	1.3	4.9	1.3	4.9	1.1	4.2	1.0	3.8	50	3.4	11	28	14	36	18	46	11	3.4



11510 Goldcoast Drive • Cincinnati, OH 45249-1621 • Phone (513) 671-3322
 FAX (513) 671-3363 • E-mail: techelp@exair.com • www.exair.com

Order Direct We Ship From Stock