

# Air Atomizing Spray Nozzles

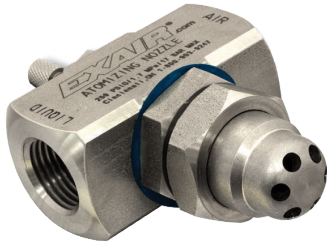

## Internal Mix Wide Angle Round Pattern - 1/2 NPT



### Model AW5010SS, AW5020SS and AW5030SS

EXAIR's 1/2 NPT internal mix wide angle round pattern atomizing nozzles are great for covering a broad area. These larger atomizing nozzles can be adjusted for a light mist or a heavy soaking spray. They are popular for dust mitigation, humidification, and cooling of products, people or livestock in a broad area. These nozzles are also perfect for applying a coating to parts packed in large containers, for example, misting a container of stamped steel parts with oil to prevent oxidation during shipment.

For pressure fed applications not requiring independent air and liquid control.

**Model: AW5010SS**  
**Material:** Type 303 Stainless Steel

**Model: AW5020SS**  
**Material:** Type 303 Stainless Steel

**Model: AW5030SS**  
**Material:** Type 303 Stainless Steel



Produce a large volume, fine mist or a hard hitting spray with these adjustable liquid nozzles.

### Dimensions and Airflow Pattern

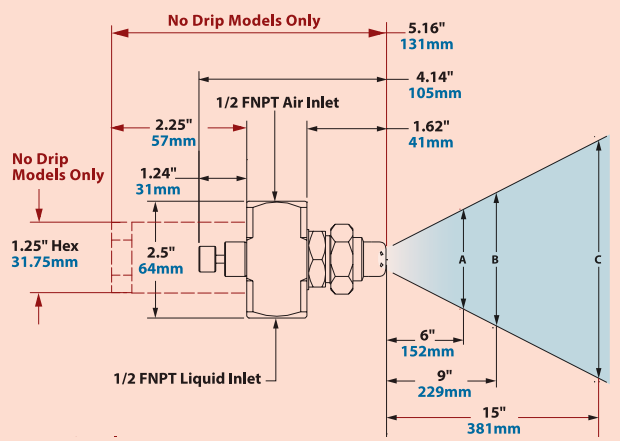

DOWNLOAD drawings at EXAIR.com

Spray Nozzles

No Drip Only Dimensions in Red  
See page 93 for No Drip Atomizing Nozzles

Model	5 PSI/0.3 BAR Liquid			15 PSI/1.0 BAR Liquid			25 PSI/1.7 BAR Liquid			35 PSI/2.4 BAR Liquid			55 PSI/3.8 BAR Liquid			Spray Dimensions																					
	Air Pressure PSI/BAR	GPH/LPH	SCFM/SLPM	Air Pressure PSI/BAR	GPH/LPH	SCFM/SLPM	Air Pressure PSI/BAR	GPH/LPH	SCFM/SLPM	Air Pressure PSI/BAR	GPH/LPH	SCFM/SLPM	Air Pressure PSI/BAR	GPH/LPH	SCFM/SLPM	Pressure			Max. Depth feet/m																		
	Pressure	Liquid	Width	A	B	C	Air PSI/BAR	Liquid PSI/BAR	A	B	C	Air PSI/BAR	Liquid PSI/BAR	A	B	C																					
AW5010SS	---	---	---	---	---	---	28	1.9	33	125	7.6	215	40	2.8	28.8	109	11.0	312	58	4.0	66	250	11.7	331	30	2.1	25	1.7	12.5	31.8	18	46	26	66	18	5.5	
	---	---	---	---	---	---	30	2.1	20.4	77	10.0	283	42	2.9	18	68	13.3	377	60	4.1	49	185	13.4	379	40	2.8	35	2.4	13	33.0	19	48	26	66	20	6.1	
	---	---	---	---	---	---	---	---	---	---	---	---	---	---	---	---	---	---	---	62	4.3	36	136	16.8	476	60	4.1	55	3.8	14	35.6	19	48	26.5	67	22	6.7
AW5020SS	10	0.69	32	121	12.0	340	26	1.8	36.8	139	21.8	617	40	2.8	60.6	229	29.9	847	54	3.7	70	265	37.4	1059	75	5.2	115	4.35	15	38.1	19.5	50	25	64	22	6.7	
	12	0.83	20.4	77	14.5	411	30	2.1	28.8	109	25.6	725	44	3.0	40.8	154	33.5	949	58	4.0	49.2	186	41.2	1167	46	3.2	25	1.7	16	40.6	20	51	25	64	35	10.7	
	14	0.97	13.2	50	16.2	459	32	2.2	21	79	27.7	784	48	3.3	26.4	100	38.2	1082	62	4.3	36	136	44.7	1266	60	4.1	35	2.4	15	38.1	18	46	22	56	40	12.2	
---	---	---	---	---	---	---	34	2.3	15.6	59	29.6	838	50	3.4	20.4	77	39.1	1107	65	4.5	27	102	46.9	1328	---	---	---	---	---	---	---	---	---	---	---	---	---
AW5030SS	10	0.69	31.2	118	12.8	362	18	1.2	112	424	14.6	413	26	1.8	180	681	17.0	481	36	2.5	210	795	21.2	600	54	3.7	264	9.99	16	40.6	21	53	31	79	20	6.1	
	12	0.83	18.6	70	15.15	429	20	1.4	87	329	16.5	467	30	2.1	138	522	20.6	583	40	2.8	177	670	25.0	708	20	1.4	15	1.0	16	40.6	20.5	52	27	69	22	6.7	
	---	---	---	---	---	---	---	22	1.5	72	273	18.5	524	36	2.5	83.4	316	26.7	756	48	3.3	102	386	32.5	920	44	3.0	35	2.4	13	33.0	17	43	22	56	35	10.7
---	---	---	---	---	---	---	24	1.7	60	227	20.4	578	40	2.8	61.2	232	31.0	878	52	3.6	82.2	311	36.7	1039	64	4.4	55	3.8	13.5	34.3	17	43	22	56	44	13.4	



11510 Goldcoast Drive • Cincinnati, OH 45249-1621 • Phone (513) 671-3322  
FAX (513) 671-3363 • E-mail: techelp@exair.com • www.exair.com

Order Direct We Ship From Stock