



# Air Atomizing Spray Nozzles

Internal Mix Wide Angle Round Pattern - 1/4 NPT



**Model: AW1010SS**  
**Material:** Type 303 Stainless Steel

**Model: AW1020SS**  
**Material:** Type 303 Stainless Steel

**Model: AW1030SS**  
**Material:** Type 303 Stainless Steel

**Model: AW1040SS**  
**Material:** Type 303 Stainless Steel

Model AW1010SS, AW1020SS, AW1030SS, and AW1040SS EXAIR's 1/4 NPT internal mix wide angle round pattern atomizing nozzles are great for covering a broad area. They can be adjusted for a light mist or a heavy soaking spray. They are popular for dust mitigation, humidification, and cooling of products, people or livestock in a broad area. These nozzles are also perfect for applying a coating to parts packed in large containers, for example, misting a container of stamped steel parts with oil to prevent oxidation during shipment.

**For pressure fed applications not requiring independent air and liquid control.**



A Model AW1030SS is used to keep dust down during charcoal briquette production.

## Dimensions and Airflow Pattern

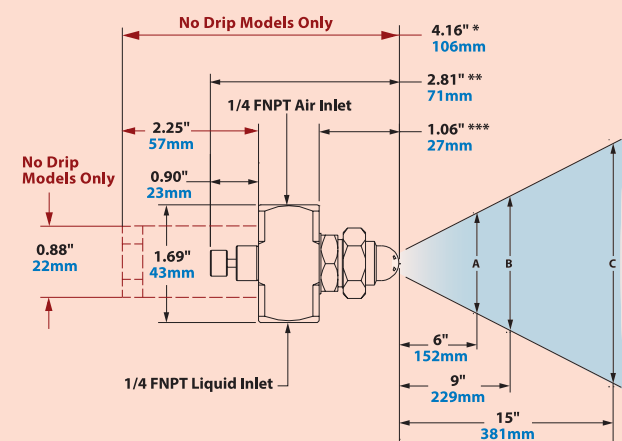

\*Model AW2010SS: 4.03" / 102mm  
\*\*Model AW1010SS: 2.68" / 68mm  
\*\*\*Model AW1010SS: 0.93" / 24mm

No Drip Only Dimensions in Red  
See page 93 for No Drip Atomizing Nozzles

Model	10 PSI/0.7 BAR Liquid					20 PSI/1.4 BAR Liquid					30 PSI/2.1 BAR Liquid					40 PSI/2.8 BAR Liquid					60 PSI/4.1 BAR Liquid					Spray Dimensions																
	Air Pressure PSI/BAR	GPH/ LPH	SCFM/ SLPM	Air Pressure PSI/BAR	GPH/ LPH	SCFM/ SLPM	Air Pressure PSI/BAR	GPH/ LPH	SCFM/ SLPM	Air Pressure PSI/BAR	GPH/ LPH	SCFM/ SLPM	Air Pressure PSI/BAR	GPH/ LPH	SCFM/ SLPM	Air Pressure PSI/BAR	GPH/ LPH	SCFM/ SLPM	Pressure Air PSI/ BAR	Pressure Liquid PSI/ BAR	Width A in	Width B cm	Width C in	Max. Depth feet/m																		
	in	cm	in	cm	in	cm	in	cm	in	cm	in	cm	in	cm	in	cm	in	cm	in	cm	in	cm	in	cm																		
AW1010SS	8	0.6	1.8	6.8	0.3	8	14	1.0	2.4	9.1	0.4	11	22	.5	2.7	10.2	0.5	14	30	2.1	3.0	11.4	0.7	20	44	3.0	3.5	13.2	0.9	25	10	0.7	10	0.7	7	18	9	23	14	36	5	1.5
	10	0.7	1.6	6.1	0.4	11	18	1.2	2.1	7.9	0.5	14	30	2.1	2.3	8.7	0.7	20	38	2.6	2.6	9.8	0.8	23	55	3.8	3.1	11.7	1.1	31	20	1.4	20	1.4	9	23	11	28	15	38	6	1.8
	12	0.8	1.5	5.7	0.4	11	22	1.5	1.9	7.2	0.6	17	36	2.5	1.9	7.2	0.8	23	46	3.2	2.1	7.9	1.0	28	65	4.5	2.5	9.5	1.3	37	34	2.3	30	2.1	10	25	12	30	16	41	8	2.4
	14	1.0	1.3	4.9	0.5	14	26	1.8	1.6	6.1	0.7	20	40	2.8	1.6	6.1	0.9	25	50	3.4	1.9	7.2	1.1	31	75	5.2	2.1	7.9	1.5	42	42	2.9	40	2.8	10	25	12	30	16	41	9	2.7
AW1020SS	12	0.8	2.8	10.6	1.7	48	22	1.5	4.0	15.1	2.3	65	30	2.1	5.4	20.4	2.5	71	38	2.6	6.4	24.2	2.9	82	54	3.7	8.5	32.2	3.5	99	12	0.8	10	0.7	10	25	13	33	17	43	9	2.7
	14	1.0	1.6	6.1	2.0	57	24	1.7	3.1	11.7	2.5	71	34	2.3	3.8	14.4	3.2	91	44	3.0	4.4	16.7	3.9	110	58	4.0	7.0	26.5	4.1	116	24	1.7	20	1.4	11	28	13	33	18	46	11	3.4
	---	---	---	---	---	---	6	1.8	2.0	7.6	2.9	82	38	2.6	1.8	6.8	4.0	113	48	3.3	2.6	9.8	4.6	130	65	4.5	5.4	20.4	5.2	147	34	2.3	30	2.1	11	28	13	33	18	46	12	3.7
	---	---	---	---	---	---	---	---	---	---	---	---	40	2.8	0.9	3.4	4.5	127	52	3.6	1.0	3.8	5.4	153	75	5.2	1.7	6.4	7.1	201	46	3.2	40	2.8	11	28	14	36	18	46	14	4.3
AW1030SS	10	0.7	6.8	25.7	1.1	31	20	1.4	8.5	32.2	1.5	42	30	2.1	9.0	34.1	2.0	57	40	2.8	10.0	37.9	2.6	74	56	3.9	15.0	56.8	2.9	82	12	0.8	10	0.7	10	25	13	33	18	46	9	2.7
	12	0.8	4.5	17.0	1.4	40	22	1.5	6.0	22.7	1.9	54	34	2.3	5.8	22.0	2.8	79	44	3.0	7.0	26.5	3.4	96	60	4.1	12.0	45.4	3.5	99	22	1.5	20	1.4	11	28	13	33	18	46	11	3.4
	14	1.0	2.2	8.3	1.9	54	24	1.7	4.5	17.0	2.3	65	38	2.6	2.4	9.1	3.8	108	48	3.3	3.7	14.0	4.2	119	70	4.8	5.0	18.9	5.6	159	34	2.3	30	2.1	11	28	14	36	18	46	13	4.0
	---	---	---	---	---	---	26	1.8	2.6	9.8	2.7	76	40	2.8	1.4	5.3	4.3	122	52	3.6	1.5	5.7	5.2	147	80	5.5	0.8	3.0	7.7	218	46	3.2	40	2.8	11	28	14	36	19	48	15	4.6
AW1040SS	24	1.7	6.0	22.7	5.4	153	38	2.6	9.3	35.2	7.7	218	48	3.3	15.5	58.7	8.4	238	60	4.1	19.3	73.1	10.3	292	85	5.9	4.0	91.0	13.8	391	12	0.8	10	0.7	10	25	14	36	16	41	16	4.9
	28	1.9	4.0	15.1	6.1	190	44	3.0	3.5	13.2	10.0	283	56	3.9	9.0	34.1	10.6	300	70	4.8	12.0	45.4	12.8	362	95	6.6	18.5	70.0	16.5	467	46	3.2	20	1.4	11	28	14	36	18	46	18	5.5
	30	2.1	2.5	9.5	6.7	190	48	3.3	3.5	13.2	10.0	283	62	4.3	6.0	22.7	12.1	343	80	5.5	6.5	24.6	14.7	416	95	6.6	18.5	70.0	16.5	467	60	4.1	30	2.1	12	30	16	41	21	53	21	6.4
	32	2.2	2.0	7.6	7.3	207	52	3.6	1.9	7.2	10.8	306	90	6.2	2.8	10.6	17.2	487	100	6.9	15.8	59.8	17.3	490	100	6.9	15.8	59.8	17.3	490	75	5.2	40	2.8	12	30	16	41	22	56	24	7.3
																														90	6.2	60	4.1	12	30	16	41	23	58	25	7.6	



# No Drip Air Atomizing Spray Nozzles



## No Drip Air Atomizing Spray Nozzles



## Eliminate drips to conserve valuable liquids and improve product finishes!

### What Are No Drip Atomizing Nozzles?

EXAIR's patented† no drip atomizing spray nozzles work in the same way our standard atomizing nozzles do, but have the added benefit of positively stopping liquid flow when compressed air is shut off. All models use stainless steel construction for durability and corrosion resistance.

*EXAIR's no drip atomizing nozzles are available in 3 basic families:*

#### Internal Mix:

Internal mix nozzles mix the liquid and air inside the air cap and produce the finest atomization. Internal mix nozzles can be used on liquids with a viscosity up to 300 cP. Both air and liquid sides are pressure fed. **No Drip Internal Mix Atomizing Nozzles are for pressure fed applications not requiring independent air and liquid control.**

#### External Mix:

External mix nozzles have the highest flow rates and allow the air and liquid flows to be adjusted independently. These nozzles are best where precise liquid flow is needed. External mix nozzles can be used on liquids with a viscosity above 300 cP. Both air and liquid sides are pressure fed. **No Drip External Mix Atomizing Nozzles are for pressure fed applications with independent air and liquid control.**

#### Siphon Fed:

Siphon fed nozzles require no liquid pressure and can be used with gravity fed liquids or lift liquids from a siphon height as much as 36 inches (91cm). Siphon fed nozzles can be used on liquids with a viscosity up to 200 cP. **No Drip Siphon Fed Atomizing Nozzles are siphon or gravity fed for non-pressurized applications.**

† Patent #9156045

### Why No Drip Atomizing Nozzles?

When spraying any type of liquid, post-spray liquid flow can cause big problems. Unwanted drips can ruin product finishes on painted or coated surfaces. In addition, excess liquid flow wastes precious resources such as expensive coatings, chemicals or water. EXAIR's no drip atomizing nozzles are ideal where no post-spray drip is permissible. When the compressed air supply is shut off, the no drip nozzle positively seals off the flow of liquid eliminating the possibility of drips. They can be used in any situation that our standard atomizing nozzles can be used, including Siphon Fed applications. Unlike some manufacturers, there's no need to run a separate air line to control the no drip mechanism. The same compressed air used to combine and atomize liquid in a variety of patterns is used to open a valve allowing liquid to flow. That makes these ideal for use with EXAIR's money and energy saving EFC (see page 7).

EXAIR's no drip nozzles do not change flow rates from standard atomizing nozzles. Operations that require up to 180 cycles per minute can be achieved. Minimum operating air pressure of 30 PSIG (2.1 BAR) required for 1/4 and 1/2 NPT nozzles. 20 PSIG (1.4 BAR) is required for 1/8 NPT nozzles.



Mounting Brackets are available - Model 901786 for 1/8 NPT, Model 901318 for 1/4 NPT and Model 901556 for 1/2 NPT atomizing nozzles.



### Applications

- Painting
- Coating
- Rinsing
- Cooling
- Quenching
- Wetting (moistening)
- Humidification
- Dust Control

### Advantages

- No post spray drip
- Adjustable
- Easily used with an EFC
- Minimizes air and liquid consumption
- All stainless steel construction
- Fine atomization
- Interchangeable liquid and air caps
- Compact

# No Drip Air Atomizing Spray Nozzles



No Drip Internal Mix Atomizing Nozzles are for pressure fed applications not requiring independent air and liquid control.



## Model Description

### No Drip Internal Mix Narrow Angle Round Pattern Atomizing Nozzles

AN9010SS	No Drip Internal Mix Narrow Angle Round Pattern Atomizing Nozzles, 2.63 GPH/9.96 LPH Max, 1/8 NPT
AN9020SS	No Drip Internal Mix Narrow Angle Round Pattern Atomizing Nozzles, 3.33 GPH/12.61 LPH Max, 1/8 NPT
AN9030SS	No Drip Internal Mix Narrow Angle Round Pattern Atomizing Nozzles, 6.3 GPH/23.85 LPH Max, 1/8 NPT
AN9040SS	No Drip Internal Mix Narrow Angle Round Pattern Atomizing Nozzles, 12.00 GPH/45.42 LPH Max, 1/8 NPT
AN9050SS	No Drip Internal Mix Narrow Angle Round Pattern Atomizing Nozzles, 18.93 GPH/71.66 LPH Max, 1/8 NPT
AN2010SS	No Drip Internal Mix Narrow Angle Round Pattern Atomizing Nozzles, 3.3 GPH/12.5 LPH Max, 1/4 NPT
AN2020SS	No Drip Internal Mix Narrow Angle Round Pattern Atomizing Nozzles, 9.9 GPH/37.5 LPH Max, 1/4 NPT
AN2030SS	No Drip Internal Mix Narrow Angle Round Pattern Atomizing Nozzles, 23.0 GPH/87.1 LPH Max, 1/4 NPT
AN2040SS	No Drip Internal Mix Narrow Angle Round Pattern Atomizing Nozzles, 66.0 GPH/250 LPH Max, 1/4 NPT
AN6010SS	No Drip Internal Mix Narrow Angle Round Pattern Atomizing Nozzles, 75.6 GPH/286 LPH Max, 1/2 NPT
AN6020SS	No Drip Internal Mix Narrow Angle Round Pattern Atomizing Nozzles, 231.0 GPH/874 LPH Max, 1/2 NPT

NO DRIP INTERNAL MIX ATOMIZING NOZZLES

Spray Nozzles

### No Drip Internal Mix Wide Angle Round Pattern Atomizing Nozzles

AW9010SS	No Drip Internal Mix Wide Angle Round Pattern Atomizing Nozzles, 2.60 GPH/9.84 LPH Max, 1/8 NPT
AW9020SS	No Drip Internal Mix Wide Angle Round Pattern Atomizing Nozzles, 9.83 GPH/37.22 LPH Max, 1/8 NPT
AW9030SS	No Drip Internal Mix Wide Angle Round Pattern Atomizing Nozzles, 15.00 GPH/56.78 LPH Max, 1/8 NPT
AW9040SS	No Drip Internal Mix Wide Angle Round Pattern Atomizing Nozzles, 22.33 GPH/84.54 LPH Max, 1/8 NPT
AW2010SS	No Drip Internal Mix Wide Angle Round Pattern Atomizing Nozzles, 3.5 GPH/13.2 LPH Max, 1/4 NPT
AW2020SS	No Drip Internal Mix Wide Angle Round Pattern Atomizing Nozzles, 8.5 GPH/32.2 LPH Max, 1/4 NPT
AW2030SS	No Drip Internal Mix Wide Angle Round Pattern Atomizing Nozzles, 15.0 GPH/56.8 LPH Max, 1/4 NPT
AW2040SS	No Drip Internal Mix Wide Angle Round Pattern Atomizing Nozzles, 24.0 GPH/91 LPH Max, 1/4 NPT
AW6010SS	No Drip Internal Mix Wide Angle Round Pattern Atomizing Nozzles, 66.0 GPH/250 LPH Max, 1/2 NPT
AW6020SS	No Drip Internal Mix Wide Angle Round Pattern Atomizing Nozzles, 115.0 GPH/435 LPH Max, 1/2 NPT
AW6030SS	No Drip Internal Mix Wide Angle Round Pattern Atomizing Nozzles, 264.0 GPH/999 LPH Max, 1/2 NPT



11510 Goldcoast Drive • Cincinnati, OH 45249-1621 • Phone (513) 671-3322  
 FAX (513) 671-3363 • E-mail: techelp@exair.com • www.exair.com

