

SENSAPHONE®

REMOTE MONITORING SOLUTIONS

SENSAPHONE Float Switch - FGD-0222
Installation Instructions

When the float switch drops to within .25" (+/- .10") of the horizontal position, the internal reed contacts draw together and complete a circuit. When the float rises .50" (+/- .10") from the horizontal position, the contacts separate and open the circuit.

Note on wiring: Do Not submerge the wires or the wire potting of any float switch in liquid. The wires should stay dry at all times.

Do Not use float switch to directly control pumps or solenoids. Float switches directly adjacent to the magnetic devices (not that many pumps use magnetic motors) or near strong magnetic fields as this may interfere with the operation of the magnetic reed inside the switch.

Do Not subject to physical shock or strong vibration. The reed switch inside the stem is encased in a glass tube and can break, causing the switch to malfunction.

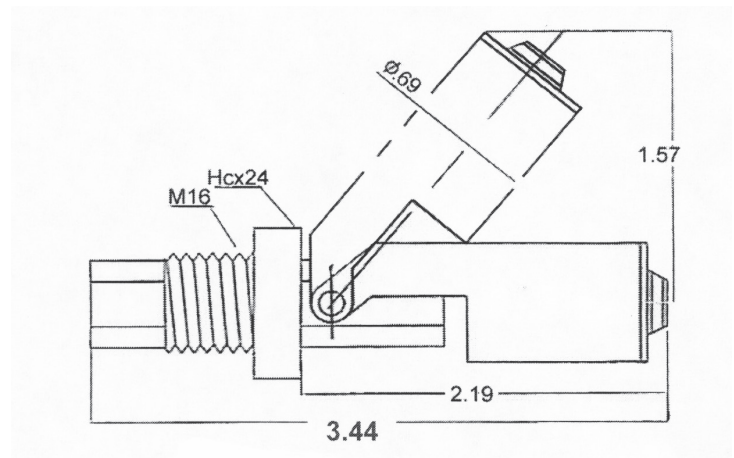
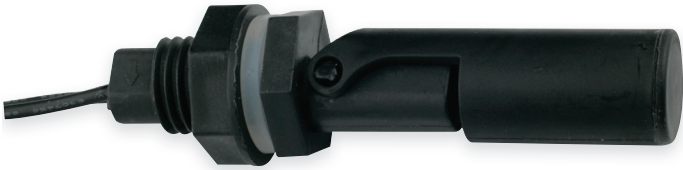

Versatile, economical, and compact.

- UL Listed internal reed switch.
- Normally closed, can be inverted for normally open operation.
- M16 stem threading – each switch comes with a nut and silicon O-ring.