

# SENSAPHONE<sup>®</sup>

## REMOTE MONITORING SOLUTIONS

### SENSAPHONE CARBON DIOXIDE (CO<sub>2</sub>) SENSOR • FGD-0068 Quick Installation Instructions

The Sensaphone Carbon Dioxide (CO<sub>2</sub>) sensor will allow you to monitor levels of Carbon Dioxide from 0-2000ppm with any Sensaphone that will accept a 4-20 Input signal. The FGD-0068 will require a 24VDC power supply to operate (Part No: FGD-0070).

Note on wiring: Use 22AWG shielded wiring for all connections (Sensaphone Part No. FGD-0010) and do not locate the device wires in the same conduit with wiring used to supply inductive loads such as motors. Disconnect the power supply before making any connections to prevent electrical shock or equipment damage. Make all connections in accordance with national and local codes.

Described below is the correct way to wire your Carbon Dioxide (CO<sub>2</sub>) Sensor to your Sensaphone.

1. Remove the cover.
2. Verify the switch in the upper left corner on the sensor is in the "OUTPUT mA" position.
3. Route the wires through the hole in the center of the circuit board.
4. Connect the 24VDC Power Supply Positive (+) to the terminal marked PWR.
5. Connect the 24VDC Power Supply Negative (-) to the Sensaphone Zone Negative (-)
6. Connect the Sensaphone Zone Negative (-) to the terminal marked COM.
7. Connect a wire from the CO<sub>2</sub> terminal to the Sensaphone Zone (+) positive terminal.
8. Replace the cover.
9. Program the Sensaphone zone (input) for a 4-20mA sensor type with a table range of 0-2,000.

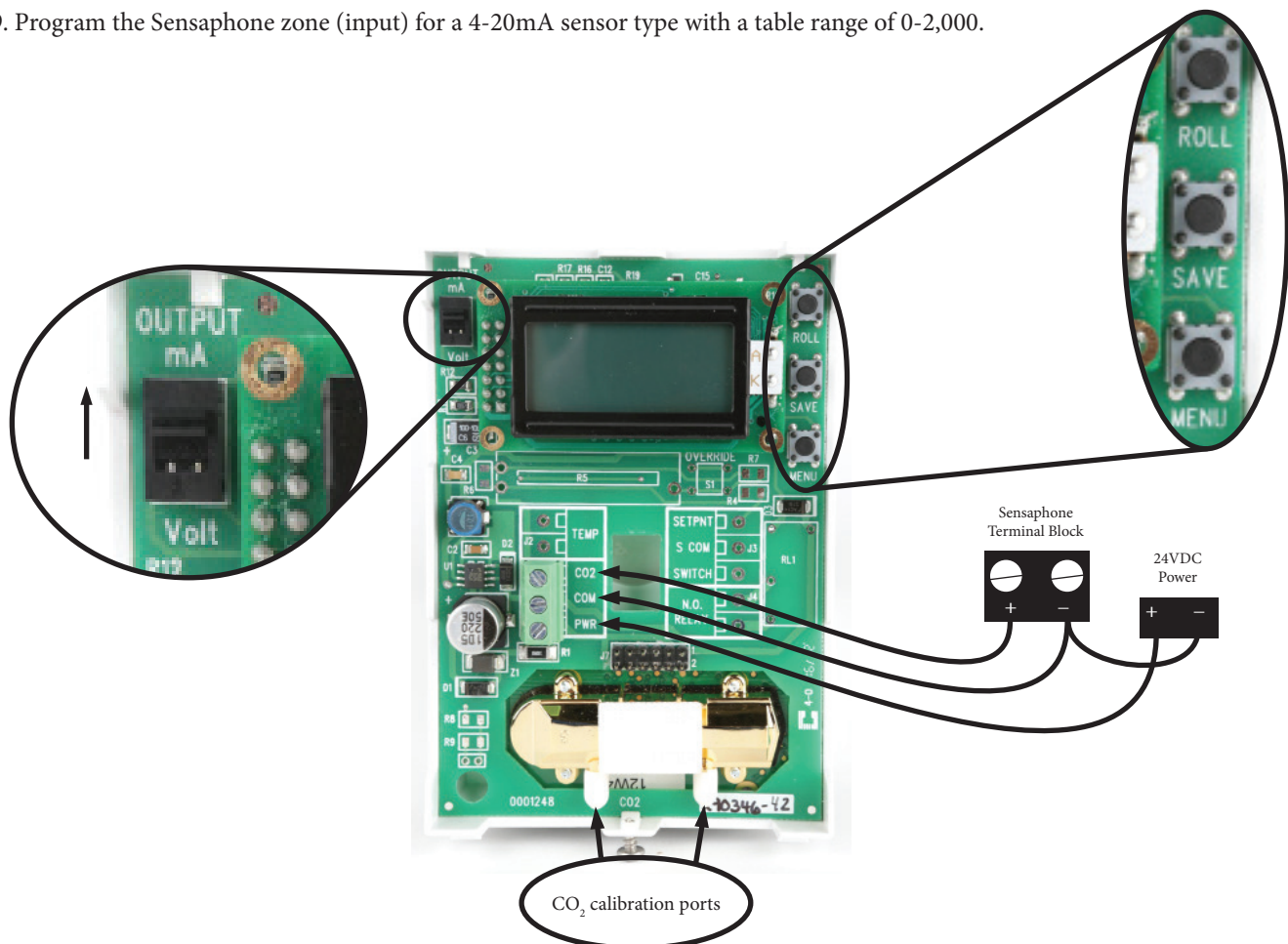

# Sensaphone FGD-0068 Carbon Dioxide (CO<sub>2</sub>) Sensor Installation Instructions and Specifications

## Introduction

The CO<sub>2</sub> transmitter uses Infrared Technology to monitor CO<sub>2</sub> levels within a range of 0 – 2000 ppm and outputs a linear 4-20 mA signal. Features include a back-lit LCD and user menu for easy installation

## Before Installation

Read these instructions carefully before installing and commissioning the CO<sub>2</sub> transmitter. Failure to follow these instructions may result in product damage. Do not use in an explosive or hazardous environment, with combustible or flammable gases, as a safety or emergency stop device or in any other application where failure of the product could result in personal injury. Take electrostatic discharge precautions during installation and do not exceed the device ratings.

## Mounting

The room type sensor installs directly on a standard electrical box and should be mounted five feet from the floor of the area to be controlled. Do not mount the sensor near doors, opening windows, supply air diffusers or other known air disturbances. Avoid areas where the detector is exposed to vibrations or rapid temperature changes.

The cover is hooked to the base at the top edge and must be removed from the bottom edge first. Use a small screwdriver to carefully pry each bottom corner if necessary. If a security screw is installed on the bottom edge, then it may have to be loosened or removed also. Tip the cover away from the base and sit it aside.

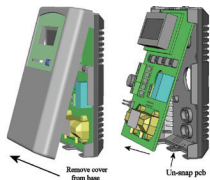

The pcb must be removed from the base to access the mounting holes. Follow usual anti-static procedures when handling the pcb and be careful not to touch the sensors. The pcb is removed

by pressing the enclosure base to unsnap the latch near the bottom edge, then the pcb can be lifted out of the base. Sit the pcb aside until the base is mounted on the wall.

After the base is screwed to an electrical box or the wall using the appropriate holes, pull the wires through the wiring hole in the center of the pcb and then reinstall it in the enclosure base. Ensure the pcb is snapped into the base securely and correctly.

The mounting hole locations are shown in the following drawing.

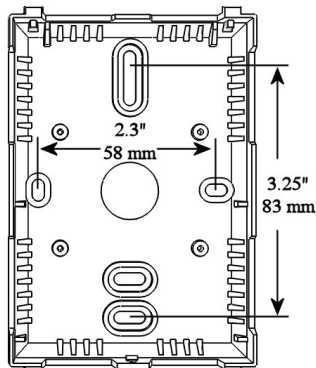

## Start Up

Verify the transmitter is properly wired and connections are tight. Ensure the output switch is set for mA. Apply power and note that the CO<sub>2</sub> sensor chamber light flashes on and off. The LCD will indicate the software version number, the output signal type, the CO<sub>2</sub> measurement range and then the sensor will begin reading the CO<sub>2</sub> level, output the correct analog signal and display the value on the LCD. The sensor operates on a 4 second interval and will update the output and display every 4 seconds.

## Output

The CO<sub>2</sub> output is scaled such that 4-20mA equals 0 to Out\_High as set in the Setup Menu. The factory default is 0-2000 ppm. Out\_High can be changed from 1000 to 7500 ppm and the output signal is scaled accordingly.

## Calibration

Calibration with gas requires a field calibration kit consisting of an LCD, a bottle of 1000 ppm CO<sub>2</sub> gas, a tank pressure regulator with flow restrictor and the necessary tubing to connect to the device.

Note that because of the Automatic Calibration Mode and other technology incorporated into this sensor, only a single point 1000 ppm calibration is required to meet specified accuracy.

Turn the regulator on/off knob fully off and attach it to the 1000 ppm CO<sub>2</sub> gas bottle and firmly tighten it by hand. Remove the cover of the unit to be calibrated to expose the gas sensor chamber. The tubing from the gas bottle can be connected to either port on the chamber after the plastic cap is removed. Gently remove one cap and connect the tubing, note that strong shock or vibration can affect calibration.

Ensure the device has been operating normally for at least five minutes before applying gas. Slowly turn the valve knob on the regulator to let the gas begin flowing.

The regulator will restrict the flow rate to the specified 100 ml/min. After a brief period the gas will flow into the chamber and the CO<sub>2</sub> reading on the LCD will begin to approach 1000 ppm. Wait 1 to 2 minutes until the CO<sub>2</sub> reading stabilizes.

Enter the Setup menu and use the <MENU> key to advance to Calibrat 1000 PPM. Press and hold the <SAVE> key for 2 seconds and the display will change to Waiting Calibrat then to Waiting 5 minute to indicate that the process of reprogramming the internal calibration setting is taking place.

This calibration process takes about 5 minutes and the LCD will count down the minutes. Do not disturb the unit or the gas flow during this period. When calibration is complete the unit will display Calibrat Done. Press the <SAVE> key to return to normal operation and then the gas can be shut off.

Disconnect the tubing and replace the cap on the sensor chamber as calibration is complete.

## Setup Menu

The menu has several items as shown below. To enter the menu, press and release the <MENU> key while in normal operation.

This will enter the SETUP menu step 1, pressing the <MENU> key a second time advances to step 2. Each press of the <MENU> key advances the menu item. No values are saved or changed by using the <MENU> key. The <ROLL> key is used to make changes to program variables by scrolling through the available options. When a value is changed, use the <SAVE> key to save it to memory and advance to the next menu item.

<MENU> Press and release the <MENU> key to enter the SETUP menu.

1. Out High      The default CO2 range is 0-2000 ppm. The span can be changed from 1000 to 7500 ppm in increments of 2000 ppm 500. Use the <ROLL> key to change the value and <SAVE> to save. The factory default is 2000 ppm.

<MENU>

2. Altitude      The default is 0 feet. Change by using the <ROLL> key from 0 to 5000 feet in 500 ft increments. Change 0 Ft for CO2 local altitude correction and press <SAVE> to save a change.

<MENU>

3. Auto Cal      Automatic Cal Mode default is ON to correct CO2 sensor drift to better than  $\pm 10$  ppm per year. Change ON with the <ROLL> key and save using <SAVE>. ON is recommended for applications where the CO2 level will be close to normal (400 ppm) at least once per day. If a building is occupied 24 hours and the CO2 level is fairly constant then this should be set to OFF.

<MENU>

4. Output      Use the <ROLL> key to toggle the output OFF (normal operation), MIN (minimum output) or MAX Test OFF (maximum output) for testing purposes. Press either <SAVE> or <MENU> to set it back to OFF and advance to the next item.

<MENU>

5. Calibrat      This item is used for 1000 ppm gas calibration and is explained in the Calibration section.

1000 PPM

<MENU>

6. BackLite      Use the <ROLL> key to enable or disable the LCD backlight. When enabled the backlight is always on, Enable when disabled it never lights. Press the <SAVE> key to save the setting. The factory default is Enable.

<MENU>

7. Restore      Press the <SAVE> key to restore all factory defaults and calibration to original factory settings.

<MENU>

8. Menu      Press <SAVE> to exit the menu and return to

normal operation or <MENU> to repeat the menu.

### General Specifications

Power Supply . . . . .	20 – 28 Vac/dc (non-isolated half-wave rectified)
Consumption . . . . .	100 mA max @ 24 Vdc, 185 mA max @ 24 Vac (with all options)
Output Signals . . . . .	4-20 mA active (sourcing), 0-5 Vdc or 0-10 Vdc (field selectable)
Output Drive Capability . . . . .	550 ohms maximum for current output, 10 Kohm min for voltage output
Output Resolution . . . . .	10 bit PWM
Protection Circuitry . . . . .	Reverse voltage protected, overvoltage protected
Operating Conditions . . . . .	0-50 °C (32-122 °F), 0-95 %RH non-condensing
Wiring Connections . . . . .	Screw terminal block (14 to 22 AWG)
Sensor Coverage Area . . . . .	100 m2 (1000 ft2) typical
Enclosure . . . . .	Wall mount enclosure, 3.3”w x 4.7”h x 1.15”d (84 x 119 x 29 mm)

### CO2 Signal

Measurement Type . . . . .	Non-Dispersive Infrared (NDIR), diffusion sampling
Measurement Range . . . . .	0-2000 ppm standard, programmable up to 7500 ppm
Standard Accuracy . . . . .	$\pm 75$ ppm @ 1000 ppm @ 22 °C (72 °F) compared to certified calibration gas
Temperature Dependence . . . . .	0.2 %FS per °C
Stability . . . . .	< 2 %FS over life of sensor (15 year typical)
Pressure Dependence . . . . .	0.13 % of reading per mm Hg
Altitude Correction . . . . .	Programmable from 0-5000 ft via keypad
Response Time . . . . .	< 2 minutes for 90 % step change typical
Warm-up Time . . . . .	< 2 minutes

### LCD Display

Resolution . . . . .	1 ppm CO2
Size . . . . .	1.4” w x 0.6” h (35 x 15 mm) alphanumeric 2 line x 8 characters
Backlight . . . . .	Enable or disable via keypad